

# HUTTRA



Design and Quality  
IKEA of Sweden



<b>ENGLISH</b>	<b>5</b>
<b>DEUTSCH</b>	<b>14</b>
<b>ITALIANO</b>	<b>23</b>
<b>FRANÇAIS</b>	<b>32</b>



## Table of contents

Safety Information	5	What to do if ...	11
Product description	8	Technical data	12
First Use	8	Environmental concerns	12
Daily use	8	IKEA GUARANTEE	13
Helpful hints and tips	9		

## Safety Information

Before using the appliance, read these safety instructions. Keep them nearby for future reference.

These instructions and the appliance itself provide important safety warnings, to be observed at all times. The manufacturer declines any liability for failure to observe these safety instructions, for inappropriate use of the appliance or incorrect setting of controls.

⚠ Very young children (0-3 years) should be kept away from the appliance. Young children (3-8 years) should be kept away from the appliance unless continuously supervised. Children from 8 years old and above and persons with reduced physical, sensory or mental capabilities or lack of experience and knowledge can use this appliance only if they are supervised or have been given instructions on safe use and understand the hazards involved. Children must not play with the appliance. Cleaning and user maintenance must not be carried out by children without supervision.

### PERMITTED USE

⚠ **CAUTION:** the appliance is not intended to be operated by means of an external switching device, such as a timer, or separate remote controlled system.

⚠ This appliance is intended to be used in household and similar applications such as: staff kitchen areas in shops, offices and other working environments; farm houses; by clients in hotels, motels, bed & breakfast and other residential environments.

⚠ This appliance is not for professional use. Do not use the appliance outdoors.

⚠ The bulb used inside the appliance is specifically designed for domestic appliances and is not suitable for general room lighting within the home (EC Regulation 244/2009).

⚠ The appliance is designed for operation in places where the ambient temperature comes within the following ranges, according to the climatic class given on the rating plate. The appliance may not work properly if it is left for a long time at a temperature outside the specified range.

Climatic class ambient temperatures:

SN: From 10°C to 32°C;

N: From 16°C to 32°C

ST: From 16°C to 38°C;

T: From 16°C to 43°C

⚠ This appliance does not contain CFCs. The refrigerant circuit contains R600a (HC).

Appliances with Isobutane (R600a): isobutane is a natural gas without environmental impact, but is flammable. Therefore, make sure the refrigerant circuit pipes are not damaged, especially when emptying the refrigerant circuit.

⚠ **WARNING:** Do not damage the appliance refrigerant circuit pipes.

⚠ **WARNING:** Keep ventilation openings, in the appliance enclosure or in the built-in structure, clear of obstruction.

⚠ **WARNING:** Do not use mechanical, electric or chemical means other than those recommended by the Manufacturer to speed up the defrost process.

⚠ **WARNING:** Ice makers and/or water dispensers not directly connected to the water supply must be filled with potable water only.

⚠ **WARNING:** Automatic ice-makers and/or water dispensers must be connected to a water supply that delivers potable water only, with mains water pressure between 0.17 and 0.81 MPa (1.7 and 8.1 bar).

⚠ Do not store explosive substances such as aerosol cans and do not place or use gasoline or other flammable materials in or near the appliance.

⚠ Do not swallow the contents (non-toxic) of the ice packs (provided with some models). Do not eat ice cubes or ice lollies immediately after taking them out of the freezer since they may cause cold burns.

⚠ For products designed to use an air filter inside an accessible fan cover, the filter must always be in position when the refrigerator is in function.

⚠ Do not store glass containers with liquids in the freezer compartment since they may break. Do not obstruct the fan (if included) with food items. After placing the food check that the door of compartments closes properly, especially the freezer door.

⚠ Damaged gaskets must be replaced as soon as possible.

⚠ Use the refrigerator compartment only for storing fresh food and the freezer compartment only for storing frozen food, freezing fresh food and making ice cubes.

⚠ Avoid storing unwrapped food in direct contact with internal surfaces of the refrigerator or freezer compartments.

Appliances could have special compartments (Fresh Food Compartment, Zero Degree Box,...). Unless differently specified in the specific booklet of product, they can be removed, maintaining equivalent performances.

⚠ C-Pentane is used as blowing agent in the insulation foam and it is a flammable gas.

The most appropriate compartments of the appliance where specific types of food are to be stored, taking into account different temperature distribution in different compartments in the appliance, are as follows:

appliance, are as follows:

- 1) Upper area of the refrigerator compartment & door - temperature zone: Store tropical fruit, cans, drinks, eggs, sauces, pickles, butter, jam
- 2) Middle area of the refrigerator compartment - cool zone: Store cheese, milk, dairy food, deli food, yoghurt
- 3) Lower area of the refrigerator compartment - coldest zone: Store cold cuts, desserts, meat and fish, cheesecake, fresh pasta, sour cream, pesto/salsa, home-cooked food, pastry cream, pudding and cream cheese
- 4) Fruit & vegetable drawer at the bottom of the refrigerator compartment: Store

vegetables and fruits (excluding tropical fruits)

5) Chiller compartment: Only store meat and fish in the coldest drawer

To avoid food contamination, please observe the following:

- Opening the door for long periods can cause a significant increase of the temperature in the compartments of the appliance.
- Regularly clean surfaces that may come into contact with food and accessible drainage systems.
- Clean water tanks (valid for some models) if they have not been used for 48 h; flush the water system connected to a water supply if water has not been drawn for 5 days.
- Store raw meat and fish in suitable containers in the refrigerator, so that it does not come into contact with or drip onto other food.
- Two-star frozen food compartments are suitable for storing pre-frozen food, storing or making ice cream and ice cubes.
- Do not freeze fresh food in one, two or three-star compartments.
- If the refrigerating appliance is left empty for long periods, switch off, defrost, clean, dry, and leave the door open to prevent mould developing inside the appliance.

## INSTALLATION

⚠ The appliance must be handled and installed by two or more persons - risk of injury. Use protective gloves to unpack and install - risk of cuts.

⚠ Installation, including water supply (if any), electrical connections and repairs must be carried out by a qualified technician. Do not repair or replace any part of the appliance unless specifically stated in the user manual. Keep children away from the installation site. After unpacking the appliance, make sure that it has not been damaged during transport. In the event of problems, contact the dealer or your nearest Aftersales Service. Once installed, packaging waste (plastic, styrofoam parts etc.) must be stored out of reach of children - risk of suffocation. The appliance must be disconnected from the power supply before any installation operation - risk of electric shock. During installation, make sure the appliance does not damage the power

cable - risk of fire or electric shock.

Only activate the appliance when the installation has been completed.

⚠ Be careful not to damage the floors (e.g. parquet) when moving the appliance. Install the appliance on a floor or support strong enough to take its weight and in a place suitable for its size and use. Make sure the appliance is not near a heat source and that the four feet are stable and resting on the floor, adjusting them as required, and check that the appliance is perfectly level using a spirit level. Wait at least two hours before switching the appliance on, to ensure that the refrigerant circuit is fully efficient.

⚠ **WARNING:** When positioning the appliance, ensure the supply cord is not trapped or damaged.

⚠ **WARNING:** To avoid a hazard due to instability, positioning or fixing of the appliance must be done in accordance with the manufacturer instructions. It's forbidden to place the refrigerator in such way that the metal hose of gas stove, metal gas or water pipes, or electrical wires are in contact with the refrigerator back wall (condenser coil).

⚠ To guarantee adequate ventilation, leave a space on both sides and above the appliance. The distance between the rear of the appliance and the wall behind the appliance should be 50 mm, to avoid access to hot surfaces. A reduction of this space will increase the Energy consumption of product.

## ELECTRICAL WARNINGS

⚠ It must be possible to disconnect the appliance from the power supply by unplugging it if plug is accessible, or by a multi-pole switch installed upstream of the socket in accordance with the wiring rules and the appliance must be earthed in conformity with national electrical safety standards.

⚠ Do not use extension leads, multiple sockets or adapters. The electrical components must not be accessible to the user after installation. Do not use the appliance when you are wet or barefoot. Do not operate this appliance if it has a damaged power cable or plug, if it is not working properly, or if it has been damaged or dropped.

⚠ If the supply cord is damaged, it must be replaced with an identical one by the manufacturer, its service agent or similarly qualified persons in order to avoid a hazard - risk of electric shock.

⚠ **WARNING:** Do not locate multiple portable socket-outlets or portable power supplies at the rear of the appliance.

**Product description**

Carefully read the operating instructions before using the appliance.

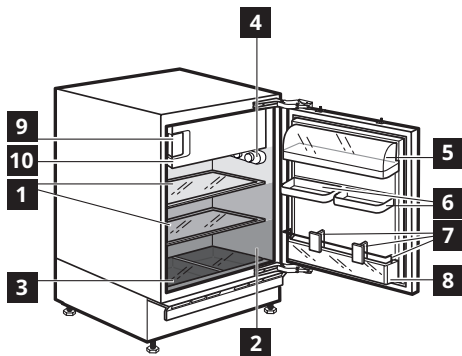

**Refrigerator compartment (for storage of fresh food and beverages)**

- 1 Glass shelves
- 2 Rating plate (at the side of crisper drawer)
- 3 Crisper drawer
- 4 Thermostat control knob/light
- 5 Dairy lid / Dairy compartment
- 6 Adjustable door balcony
- 7 Metal wire and bottle divider
- 8 Bottle balcony

**Freezer compartment (marked with the symbol for storing fresh food, frozen food and making ice cubes)**

- 9 Ice cube tray
  - 10 Low Temperature compartment door
- Least cold zone
  - Intermediate temperature zone
  - Coldest zone

**Accessories**

Egg tray

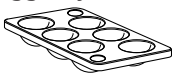

1x

Ice tray

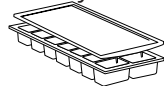

1x

Ice scraper

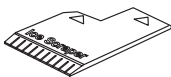

1x

Features, technical information and images may vary depending on model

**First Use**

Connect the appliance to the power supply. The ideal food storage temperatures are already factory-set (intermediate).

To avoid food waste, please refer to the recommended setting and storage times found in the user manual.

Note: after being switched on, the appliance needs 4-5 hours in order to reach the correct temperature to store a typical volume of food.

**Important!**

This appliance is sold in France. In accordance with regulations valid in this country it must be provided with a special device (see figure) placed in the lower compartment of the fridge to indicate the coldest zone of it.

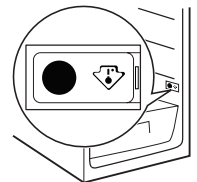

**Daily use**

**Refrigerator and freezer operation**

The appliance's refrigerator compartment features a control panel with LED lights. A different temperature can be set using the **C** button as shown in the figure.

The three green LED indicators indicate the refrigerator compartment set temperature.

The following adjustments are possible:

Leds on Set temperature

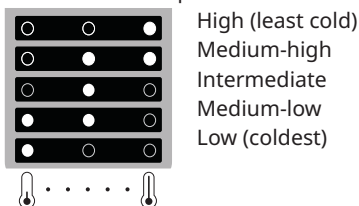

**Stand-by**

Press the **C** button for 3 seconds to deactivate the appliance (the control panel and lights remain off). Press the button again briefly to reactivate the appliance.

Note: This operation does not disconnect the appliance from the power supply.

Note: the ambient temperature, frequency of door opening and position of the appliance can affect the temperature inside the two compartments.

These factors must be taken into account when setting the thermostat.



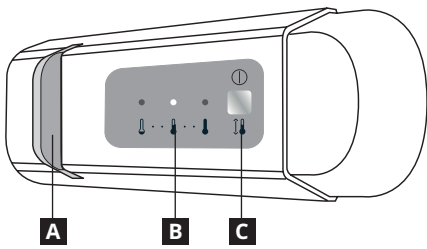

- A** Led light
- B** Refrigerator compartment temperature
- C** Button for temperature regulation and Stand-by function

**LED light**

LEDs last longer than traditional light bulbs, improve internal visibility and are environmentally friendly. Contact the Service Centre if replacement is necessary.

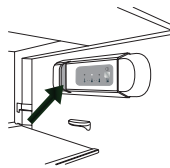
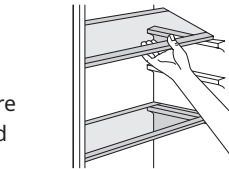

**Refrigerator compartment**

Refrigerator compartment defrosting is completely automatic. Droplets of water on the rear wall inside the refrigerator compartment indicate that the automatic defrost phase is in progress. The defrost water is automatically run into a drain hole and collected in a container, where it evaporates.

**Caution!** The refrigerator accessories must not be placed in a dishwasher

**Movable shelves**

The walls of the refrigerator are equipped with a series of runners so that the safety glass shelves can be positioned as desired. For better use of space, the front halfshelves can lie over the rear ones.

**Freezer compartment**

This appliance is a refrigerator with a **\*\*\*** star rating freezer compartment. Packed frozen foods can be stored for the period indicated on the packing. Fresh food can also be frozen, ensuring that any contact with already frozen food is avoided. The quantity of fresh food that can be frozen in a 24 hour period is given on the rating plate. Re-freezing of partially defrosted food is not recommended. This food should be consumed within 24 hours. For further information on freezing fresh food, refer to the quick guide.

**Freezing fresh food**

Place the fresh food to be frozen inside the freezer compartment. Avoid direct contact with already frozen food. To freeze the quantity of food shown on the serial tag, remove the top drawer and place the food directly on the rack.

**Making ice cubes**

Fill the ice cube tray up to 2/3 with water and place in the freezer compartment. Do not use sharp or pointed objects to detach the tray.

**Helpful hints and tips**

**Hints for energy saving**

- Do not open the door frequently or leave it open longer than absolutely necessary.
- If the ambient temperature is high, the temperature regulator is on the higher setting and the appliance is fully loaded, the compressor may run continuously, causing frost or ice on the evaporator. If this happens, turn the temperature regulator toward lower settings to allow automatic defrosting and so a saving in electricity consumption.

**Hints for fresh food refrigeration**

To obtain the best performance:

- Do not store warm food or evaporating liquids in the refrigerator.
- Do cover or wrap the food, particularly if it has a strong flavour.
- Position food so that air can circulate freely around it.

**Hints for refrigeration**

- Meat (all types) : wrap in polythene bags and place on the glass shelf above the vegetable drawer. For safety, store in this way only one or two days at the most.
- Cooked foods, cold dishes, etc.: these should be covered and may be placed on any shelf.
- Fruit and vegetables: these should be thoroughly cleaned and placed in the drawer.
- Butter and cheese: these should be placed in special airtight containers or wrapped in aluminium foil or polythene bags to exclude as much air as possible.
- Milk bottles: these should have a cap and should be stored in the bottle rack on the door.
- Bananas, potatoes, onions and garlic: if not packed, must not be kept in the refrigerator.

**Hints for freezing**

To help you make the most of the freezing process, here are some hints:

- The maximum quantity of food which can be frozen in 24

- hours is shown on the rating plate.
- The freezing process takes 24 hours. No further food to be frozen should be added during this period.
- Freeze only top quality, fresh and thoroughly cleaned foodstuffs.
- Prepare food in small portions to enable it to be rapidly and completely frozen and to make it possible subsequently to thaw only the quantity required.
- Wrap up the food in aluminium foil or polythene and make sure that the packages are airtight.
- Do not allow fresh, unfrozen food to touch food which is already frozen, thus avoiding a rise in temperature of the latter.
- Lean foods store better and longer than fatty ones; salt reduces the storage life of food.
- Water ices, if consumed immediately after removal from the freezer compartment, can possibly cause the skin to be freeze burnt.
- It is advisable to show the freezing in date on each individual pack to enable you to keep tab of the storage time.

**Hints for storage of frozen food**

To obtain the best performance from this appliance, you should:

- Make sure that the commercially frozen foodstuffs were adequately stored by the retailer.
- Make sure that frozen foodstuffs are transferred from the foodstore to the freezer in the shortest possible time.
- Do not open the door frequently or leave it open longer than absolutely necessary.
- Once defrosted, food deteriorates rapidly and cannot be refrozen.
- Do not exceed the storage period indicated by the food manufacturer.

## Cleaning and Maintenance

Regularly clean the appliance with a cloth and a solution of hot water and neutral detergent specifically formulated for refrigerator interiors. Do not use abrasive cleaners or tools. Use the tool provided to regularly clean the defrost water drain outlet, located on the rear wall of the refrigerator compartment near the crisper draw, in order to ensure defrost water is removed correctly (see Fig. 1). Before servicing or cleaning the appliance, unplug it from the mains or disconnect the power supply.

**Fig. 1**

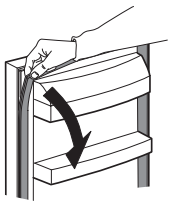
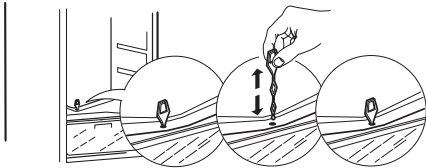

The push in gasket allows it to be cleaned easily, simply removing it from its place, starting from the upper corner part as shown, and then reinserting it using the reverse procedure used to remove it.

### Defrosting the freezer compartment

It is perfectly normal for ice to form. The amount of ice which forms and the rate at which it accumulates will depend on ambient temperature and humidity, and on the frequency of door opening.

Set the coldest temperature four hours before removing food from the freezer compartment, so as to extend the storage time of food during defrosting.

To defrost, switch the appliance off and remove the drawers. Place the frozen food in a cool place.

Leave the freezer door open to allow the frost to melt.

To prevent water leaking onto the floor during defrosting, place an absorbent cloth on the bottom of the freezer compartment and wring it out regularly.

Clean the interior of the freezer. Rinse and dry carefully.

Switch the appliance on again and place food back in the freezer compartment.

### Food storage

Wrap food to protect it from any water, humidity or condensation; this will prevent the spread of any odours in the refrigerator, while also ensuring better storage of frozen food. Never place warm food in the freezer. Cooling hot foods before freezing saves energy and prolongs the life of the appliance.

### If the event of prolonged disuse

Disconnect the appliance from the power supply, remove all food, defrost and clean the appliance. Leave the doors open just enough to allow air to circulate inside the compartments. This will prevent the formation of mould and unpleasant odours.

### In the event of a power cut

Keep the doors of the appliance closed. This will allow the food to stay cold as long as possible. If food has defrosted even partially, do not re-freeze it. Consume within 24 hours.

**What to do if ...**

Problems...	Possible causes...	Solutions...
The appliance does not operate	There might be a problem with the electric power supply to the appliance.	Check that: <ul style="list-style-type: none"> <li>• there isn't a power supply failure</li> <li>• the power plug is correctly inserted in the power socket and the two-pole switch, if present, is in the correct position (on)</li> <li>• the electric circuit safety devices installed in the house are fully functional</li> <li>• the power supply cable is not broken</li> </ul>
The inside LED light bulb does not work.	The LED light bulb might need replacing.	Disconnect the appliance from the electric power supply, check the LED light bulb and replace with a new one if necessary (see "Daily use").
The temperature inside the compartments is not cold enough.	There may be several causes (see "Solutions")	Check that: <ul style="list-style-type: none"> <li>• The doors are closed correctly</li> <li>• The appliance is not placed near a heat source.</li> <li>• the temperature set is appropriate.</li> <li>• Air circulation through the ventilation grills at the bottom of the appliance is not obstructed.</li> </ul>
There is water at the bottom of the refrigerator compartment	The defrost water drain is obstructed. The drain hose is not in the compressor tray	Clean the defrost water drain hole (see "Cleaning and maintenance"). Check that: <ul style="list-style-type: none"> <li>• The tube is correctly inserted in the tray</li> </ul>
The inside light flashes	"Door open" alarm active. It is activated when the refrigerator compartment door remains open for a prolonged period of time.	To stop the alarm, close the refrigerator door. On reopening the door, check the light works

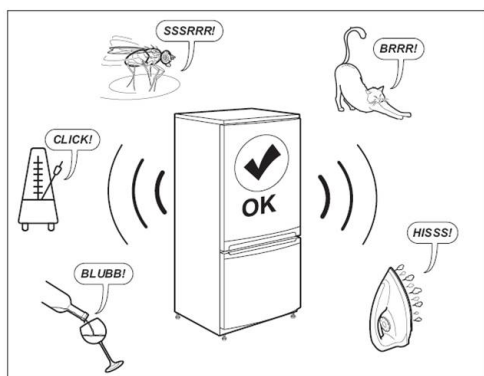

**Note:**

Gurgling, hissing and humming noises from the refrigerating system are normal.

**Before contacting the After-Sales Service:**

Switch the appliance on again to see if the problem has disappeared. If not, switch it off again and repeat the operation after an hour.

If your appliance still does not work properly after carrying out the checks listed in the troubleshooting guide and switching the appliance on again, contact the After-sales service, clearly explaining the problem and specifying:

- the type of fault;
- the model;

- the type and serial number of the appliance (given on the rating plate);
- the Service number (the number after the word SERVICE on the rating plate inside the appliance).

**SERVICE** 0000 000 00000



Technical data

Dimensions	HUTTRA
Height (min-max)	819-899
Width	597
Depth	545
<b>Net Volume (l)</b>	
Refrigerator	108
Freezer	18
<b>Defrost system</b>	
Refrigerator	Automatic
Freezer	Manual
<b>Star Rating</b>	4
<b>Rising Time (h)</b>	11
<b>Freezing capacity (kg/24 h)</b>	3
<b>Energy consumption (kwh/Year)</b>	187
<b>Noise level (dba)</b>	38
<b>Energy class</b>	F

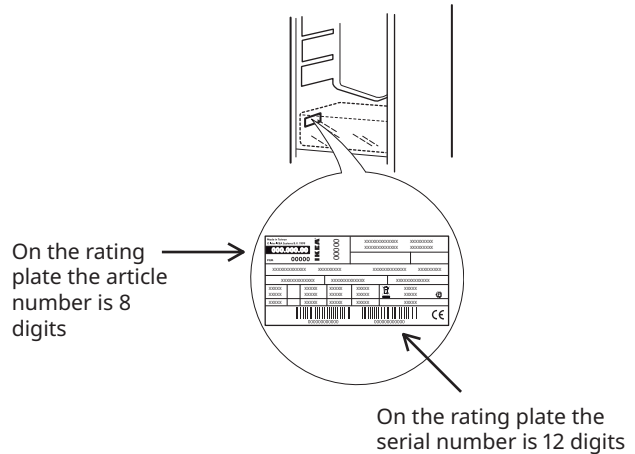

The technical information is situated in the rating plate on the internal side of the appliance and in the energy label. The model information can be retrieved using the QR-Code reported in the energy label. The label also includes the model identifier that can be used to consult the portal of the registry at <https://eprel.ec.europa.eu>

Environmental concerns

**⚠WARNING:** Ensure that the appliance is switched off and disconnected from the power supply before performing any maintenance operation. To avoid risk of personal injury use protective gloves (risk of laceration) and safety shoes (risk of contusion); be sure to handle by two persons (reduce load); never use steam cleaning equipment (risk of electric shock). Non-professional repairs not authorized by the manufacturer could result in a risk to health and safety, for which the manufacturer cannot be held liable. Any defect or damage caused from non-professional repairs or maintenance will not be covered by the guarantee, the terms of which are outlined in the document delivered with the unit.

**Disposal of packaging materials**

The packaging material is 100% recyclable and is marked with the recycle symbol. ♻

The various parts of the packaging must therefore be disposed of responsibly and in full compliance with local authority regulations governing waste disposal.

**Scrapping of household appliances**

This appliance is manufactured with recyclable or reusable materials. Doors and lids of the refrigeration appliance should be removed before disposal in the landfill, to avoid children or animals getting trapped inside. Dispose of it in accordance with local waste disposal regulations. For further information on the treatment, recovery and recycling of household electrical appliances, contact your local authority, the collection service for household waste or the store where you purchased the appliance. This appliance is marked in compliance with European Directive 2012/19/EU, Waste Electrical and Electronic Equipment (WEEE). By ensuring this product is disposed of correctly, you will help prevent negative consequences for the environment and human health.

The symbol on the product or on the accompanying documentation indicates that it should not be treated as domestic waste but must be taken to an appropriate collection center for the recycling of electrical and electronic equipment.

**Energy saving tips**

To guarantee adequate ventilation follow installation instructions. Insufficient ventilation on back of the product increases energy consumption and decreases cooling efficiency.

**Frequent door opening might cause an increase in Energy consumption.**

The internal temperature of the appliance **and the Energy Consumption** may be affected also by the ambient temperature, as well as location of the appliance. Temperature setting should take into consideration these factors.

Reduce to a minimum door opening.

When thawing frozen food, place them in the refrigerator.

The low temperature of the frozen products cools the food in the refrigerator. Allow warm food and drinks to cool down before placing in the appliance.

Positioning of the drawers, baskets and shelves in the refrigerator has no impact on the efficient usage of energy. Food should be placed on the shelves in such way to ensure proper air circulation (food should not touch each other and distance between food and rear wall should be kept).

You can increase storage capacity of frozen food by removing baskets and, if present, Stop Frost shelf, maintaining an equivalent energy consumption.

Do not worry of the noise coming from the compressor which are normal operation noises.

**Declaration of conformity**

- This appliance has been designed for preserving food and is manufactured in compliance with Regulation (CE) No. 1935/2004.

This appliance has been designed, manufactured and marketed in compliance with:

- safety objectives of the "Low Voltage" Directive 2014/35/CE (which replaces 2006/95/CEE and subsequent amendments);
- the protection requirements of Directive "EMC" 2014/30/EC.



## IKEA GUARANTEE

### How long is the IKEA guarantee valid?

This guarantee is valid for five years from the original date of purchase of your appliance at IKEA. The original sales receipt, is required as proof of purchase. If service work is carried out under guarantee, this will not extend the guarantee period for the appliance.

### Who will execute the service?

IKEA service provider will provide the service through its own service operations or authorized service partner network.

### What does this guarantee cover?

The guarantee covers faults of the appliance, which have been caused by faulty construction or material faults from the date of purchase from IKEA. This guarantee applies to domestic use only. The exceptions are specified under the headline "What is not covered under this guarantee?" Within the guarantee period, the costs to remedy the fault e.g. repairs, parts, labour and travel will be covered, provided that the appliance is accessible for repair without special expenditure. On these conditions the EU guidelines (Nr. 99/44/EG) and the respective local regulations are applicable. Replaced parts become the property of IKEA.

### What will IKEA do to correct the problem?

IKEA appointed Service Provider will examine the product and decide, at its sole discretion, if it is covered under this guarantee. If considered covered, IKEA Service Provider or its authorized service partner through its own service operations, will then, at its sole discretion, either repair the defective product or replace it with the same or a comparable product.

### What is not covered under this guarantee?

- Normal wear and tear.
- Deliberate or negligent damage, damage caused by failure to observe operating instructions, incorrect installation or by connection to the wrong voltage, damage caused by chemical or electrochemical reaction, rust, corrosion or water damage including but not limited to damage caused by excessive lime in the water supply, damage caused by abnormal environmental conditions.
- Consumable parts including batteries and lamps.
- Non-functional and decorative parts which do not affect normal use of the appliance, including any scratches and possible color differences.
- Accidental damage caused by foreign objects or substances and cleaning or unblocking of filters, drainage systems or soap drawers.
- Damage to the following parts: ceramic glass, accessories, crockery and cutlery baskets, feed and drainage pipes, seals, lamps and lamp covers, screens, knobs, casings and parts of casings. Unless such damages can be proved to have been caused by production faults.
- Cases where no fault could be found during a technician's visit.
- Repairs not carried out by our appointed service providers and/or an authorized service contractual partner or where non-original parts have been used.
- Repairs caused by installation which is faulty or not according to specification.
- The use of the appliance in a non-domestic environment i.e. professional use.
- Transportation damages. If a customer transports the product to his home or another address, IKEA is not liable for any damage that may occur during transport. However, if IKEA delivers the product to the customer's delivery address, then damage to the product that occurs during this delivery will be covered by IKEA.
- Cost for carrying out the initial installation of the IKEA appliance.
- However, if an IKEA appointed Service Provider or its authorized service partner repairs or replaces the appliance under the terms of this guarantee, the appointed Service Provider or its authorized service partner will reinstall the repaired appliance or install the replacement, if necessary.

- This does not apply within Ireland, customer should contact the local IKEA dedicated after sales line or the appointed Service Provider for further information.  
**(just for GB)**

These restrictions do not apply to fault-free work carried out by a qualified specialist using our original parts in order to adapt the appliance to the technical safety specifications of another EU country.

### How country law applies

The IKEA guarantee gives you specific legal rights, which cover or exceed all the local legal demands. However these conditions do not limit in any way consumer rights described in the local legislation.

### Area of validity

For appliances which are purchased in one EU country and taken to another EU country, the services will be provided in the framework of the guarantee conditions normal in the new country.

An obligation to carry out services in the framework of the guarantee exists only if the appliance complies and is installed in accordance with:

- the technical specifications of the country in which the guarantee claim is made;
- the Assembly Instructions and User Manual Safety Information.

### The dedicated AFTER SALES for IKEA appliances

Please don't hesitate to contact IKEA appointed Authorized Service Centre to:

- make a service request under this guarantee;
- ask for clarifications on installation of the IKEA appliance in the dedicated IKEA kitchen furniture;
- ask for clarification on functions of IKEA appliances.

To ensure that we provide you with the best assistance, please read carefully the Assembly Instructions and/or the User Manual before contacting us.

### How to reach us if you need our service



Please refer to the last page of this manual for the full list of IKEA appointed Authorized Service Centre and relative national phone numbers.

- i** In order to provide you a quicker service, we recommend to use the specific phone numbers listed on this manual. Always refer to the numbers listed in the booklet of the specific appliance you need an assistance for. Please also always refer to the IKEA article number (8 digit code) and 12 digit service number placed on the rating plate of your appliance.

### **i** SAVE THE SALES RECEIPT!

It is your proof of purchase and required for the guarantee to apply. The sales receipt also reports the IKEA name and article number (8 digit code) for each of the appliances you have purchased.

### Do you need extra help?

For any additional questions not related to After Sales of your appliances please contact your nearest IKEA store call centre. We recommend you read the appliance documentation carefully before contacting us.